

UCR 80 Undercurrent Relay

INSTALLATION AND SETTING UP PROCEDURE

1. Protection Features

Possible applications:

- Sensing of blocked deliveries or loss of prime on pump applications
- Warning of low motor efficiency as a result of impellor wear
- Warning in respect of broken couplings, belts, or motors running idle
- Warning of broken V belts or blocked filters

2. Description of Operation

The unit has a detection level of $\pm 1\%$ and a repeatability of $\pm 1\%$ making it one of the most accurate undercurrent detection devices on the market.

The NewElec UCR80 undercurrent detection relay is designed for monitoring current on one phase only and is a chassis-mounted unit. The relay consists of a detachable chassis-mounted 12-pin plug-in base, upon which the hard wiring is facilitated (refer diagram). Once the wiring is completed the actual relay is then pushed firmly into place. Securing screws on the top and bottom of the relay holds the relay body firmly in position. The relay is designed to accommodate an input current of 1 Amp across terminals 2 and 3 and an auxiliary supply voltage of either 110 OR 220 Volt a.c is required across terminals 10 and 12 OR 10 and 11 respectively.

Note that the load setting dial (top dial) is calibrated in percentage. The range being 30 to 120% of the current transformer ratio. It is therefore essential that the selected current transformer (xxx:1) be selected to cover the current range you desire to monitor. For example, a 50:1 current transformer would permit the monitoring of currents from 15 Amp (30% of 50 Amp) to 60 Amp (120% of 50 Amp). Should your application require that lower or higher currents be monitored simply select suitable current transformer ratios. Should an existing installation already incorporate a current transformer with a 5 amp secondary output (xxx:5), it will become necessary to include an interposing current transformer of 5:1 in order to match the current input requirements of the relay.

The relay is designed fail safe so that disruption of the auxiliary supply voltage to the relay will cause the main normally closed change-over trip (terminals 9 and 7) contact to de-energise. The relay incorporates a separate immediate alarm change-over contact (terminals 4,5 and 6) which energises immediately the moment an underload condition is detected by the relay.

UCR 80 UNDERCURRENT RELAY

Note that the main Trip Delay Timer is calibrated from 5 to 50 seconds (bottom dial).

After a trip condition, the relay will reset in accordance with a control panel-mounted toggle switch selected to automatic or manual reset. Automatic reset will cause the main trip relay to re-energise after a 1 second delay while a control panel-mounted reset pushbutton will need to be pressed if left in the manual reset condition.

Three LEDs are incorporated on the relay control panel. These, from top to bottom, serve to provide the following functions:

- (a) Power LED
Simply indicates the presence of auxiliary supply power on the relay and that the unit is either in use or ready for operation.
- (b) Min Load % C.T. Ratio LED
This LED indicates that the actual load current flowing in the current transformer primary is less than the set threshold on the Min Load % C.T. Ratio dial and that the trip delay timer has been initiated. The trip delay timer will be reset if the load current increases above the set threshold prior to the "Trip Delay" period having expired. If this does not occur the main trip relay will be operated on expiry of the user selected timing out period (range 5 to 50 seconds).
- (c) Trip LED
This LED is used to indicate that the "Main Trip" relay has operated. This LED is situated at the bottom of the relay control panel.

Under normal operation, terminals 9 and 7 of the main trip contact will be wired in series with the main contactor holding coil while terminals 4 and 6 of the separate alarm relay would be connected to an alarm annunciating circuit. The power LED will be illuminated. Upon the detection of an underload condition, the alarm trip contact will be energised and the main trip delay timer will initiate. At the same time, the minimum load LED will illuminate. Should the motor load increase above the user selected undercurrent detection threshold before the main trip delay timer has timed out, the alarm contact will de-energise and the main trip delay timer will reset. At this point the minimum load LED would extinguish. If, however, the underload condition persists the main trip contact will de-energise on completion of the user selected time delay period and the main trip LED will be illuminated.

3. Information required for Initial Settings

A knowledge of the value of the no load current condition so as to select an appropriate current transformer.

The trip delay period appropriate for the protection of the motor/ application.

4. Setting up Procedure

- Check that the motor full load current is less than 120% of the sensing current transformer. Now set the Min Load % C.T. Ratio to either:
 - (a) The calculated % current value desired or
 - (b) Continue as described below
- Set the Min Load % C.T. Ratio to maximum value of (30%).
- Set the Trip Delay Timer to a time period corresponding with a time period for which the machine or device can safely tolerate an underload condition.
- Apply power to terminals 10 and 11 OR 10 and 12 as appropriate. (Power LED switches on and output relay energises).
- Start machine or device. Once the motor has settled to the normal running load increase (turn clockwise) the Min Load % C.T. Ratio dial until the LED switches on. Reduce the setting by 5% and leave as a final setting.

5. Adding or Removing Features on Site

There are no features to be added or removed on site.

6. Specifications

INPUT CONVERTOR

Overload : 600% Load setting 5 min.
Capacity : 800% Load setting 1 min.

LOAD LEVEL SETTING

Span : 30% to 120% In.
Level setting accuracy : 4%
Linearity : 4%
Detection level : 4%
Repeatability : 1%

TRIP DELAY

UCR 80 : 5 to 50 sec
Level setting : 4%
Linearity : 4%
Time accuracy : 10%

AUXILIARY AND MAIN TRIP RELAY CONTACTS

Rating : 6 amps 220 Vac
Configuration : 1 x Form C

CONTROL SUPPLY

220 Vac : $\pm 10\%$
110 Vac : $\pm 10\%$
Frequency : 42 - 67 Hz
Power : 1,5 Va.
Fail-safe operation : Unit trips on loss of control supply

7. Dimensional Diagram

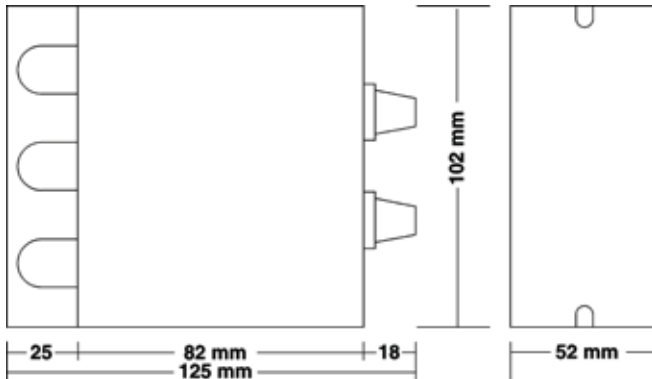

8. Electrical Connection Diagram

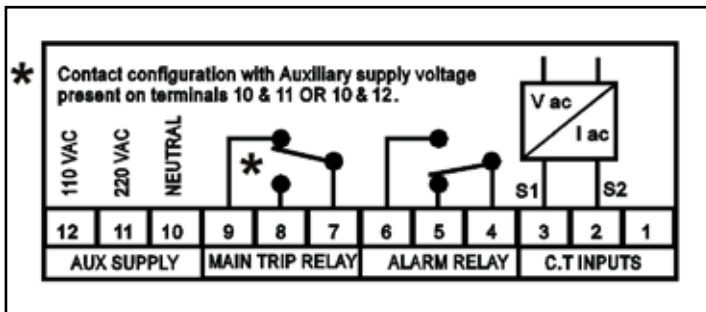

9. Ordering Information

MODELS: UCR 80/MC/1/S

NEW ELEC

MOTOR PROTECTION & CONTROL TECHNOLOGY

298 Soutter Street, Pretoria West
 Postnet Suite #73, Private Bag X06, Quagga, 0058
 Tel: (012) 327-1729 Fax: (012) 327-1733
 E-mail: sales@newelec.co.za Http://www.newelec.co.za