

# NEW ELEC

MOTOR PROTECTION & CONTROL TECHNOLOGY

## 320- 327 Series

**Comprehensive  
Protection for Low  
and Medium Voltage  
Motors**



*A South African Company to be Proud of*

## **About**

The 320 - 327M Series of electronic motor protection relays provide comprehensive protection required by motors running constantly at full load and occasionally beyond their limitations. Motors driving crushers, ball mills or high inertia loads especially with long run-up starting times are ideal applications.

Thermal overload protection, running stall and jam protection, earth fault and short circuit protection along with selectable start attempt limitations are features of the relay. A built in motor load current transducer is useful for indicating the % motor load through the 4- 20mA Loop.

Available in Amp calibration range from 0,8A to 1680A split over 7 Amperage selection bands. Also available in a % calibration with the maximum load setting expressed as the full load current divided by the C.T. ratio and multiplied by 100.

## **Features Include:**

The NewElec OLR 8 is able to prevent mechanical breakdowns related to impact torque conditions such as:

- Thermal Overload Protection
- Locked Rotor Protection
- Running Stall Protection – Jam Protection
- Unbalanced Current Protection
- Single Phasing Protection
- Earth Leakage Protection
- Earth Fault Protection
- Short Circuit Protection
- Starts per Hour Limitation
- 4-20mA Loop output

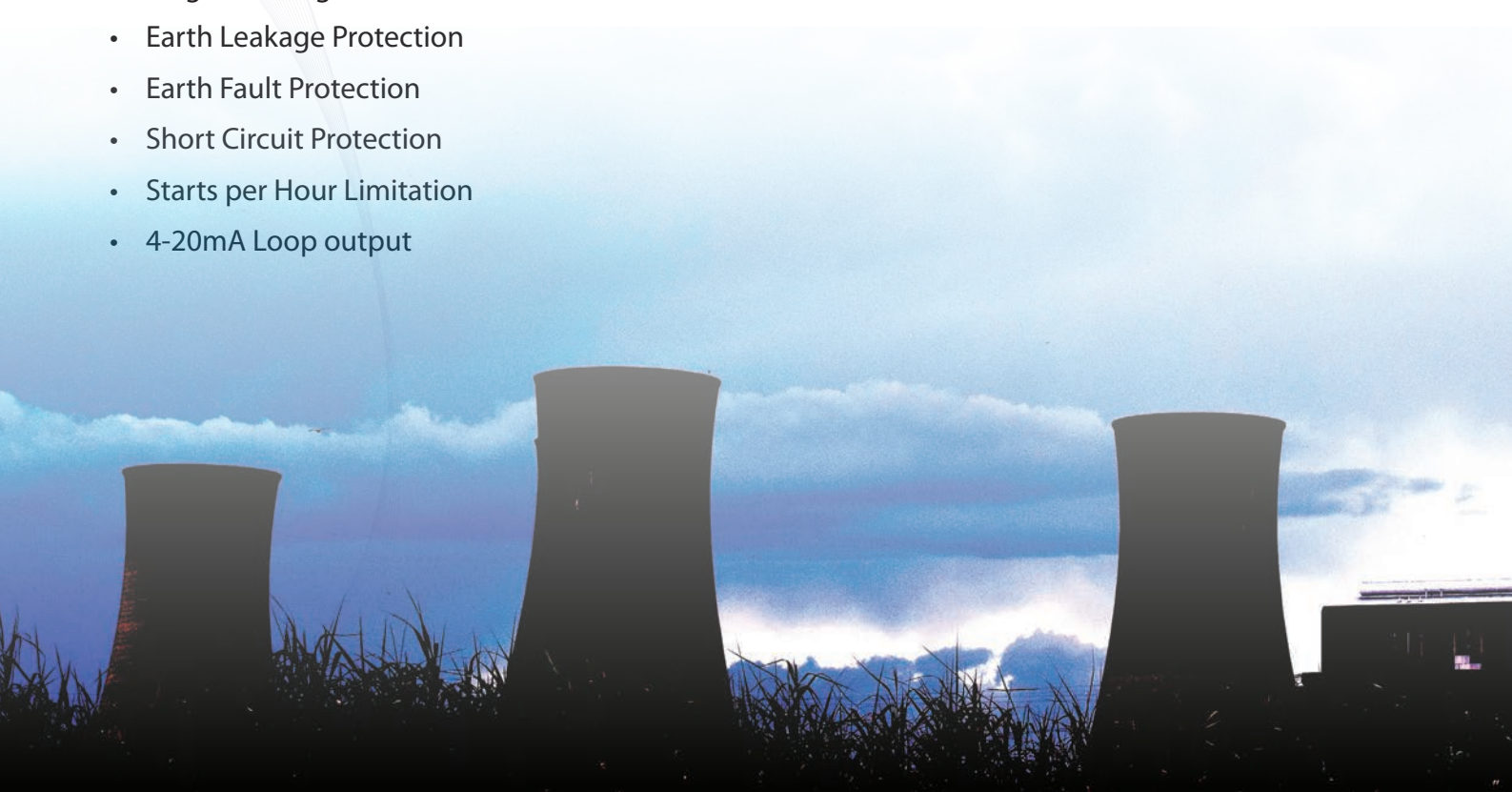

## Ordering Information

C.T. Ratio	Recommended Range (Amps)	Code	Mounting Code	Control Supply	Running Stall	C.T.
20:1	0,8 to 12	0			A: 3 x M.L.C.	
50:1	13 to 30	1		110: 110V AC 5VA		
100:1	31 to 80	2	Flush : F		B: 2,5 x M.L.C.	1: 1A Sec
200:1	80 to 160	3				
500:1	160 to 400	4	Chassis: C		C: 2 x M.L.C.	
1000:1	400 to 800	5		220: 220V AC 5VA		5: 5A Sec
2000:1	800 to 1680	6			D: 1,5 x M.L.C.	
Xxx:1	30% to 115%	7				

**Example:** NewElec 32 3 M F 220 A 1

Code:	Options
F	Immediate overload warning (Option I, O and P disallowed)
G	Earth Fault
H	Short Circuit
I	Transfer options G and H to auxiliary relay (option F and O disallowed) with 1 s delay on main trip relay
J	100ms trip time for options G and H(if not selected, 1 s delay will be selected)
K	Thermal memory override facility
L	Motor Load and thermal memory analogue indication meter (29m or 39m)
M	Auto-manual overload trip reset facility
N	Programmed limitation of start attempts (1, 2 or 3)
O	Phase unbalanced alarm - trip function disabled (option I, O and P disallowed)
P	Slave auxiliary relay with main trip relay (option I, O and P disallowed)

**Example: NewElec 32 3 M F 220 A 1 G H K**



## Input Converter

Overload Capacity : 6 x Maximum Load

### Current setting cont.

: 8 x Maximum Load control setting for 5 min

Frequency Response : 42 to 66 Hz

### Unbalance Current Sensor

Level Setting Accuracy :  $\pm 4\%$

Linearity:  $\pm 4\%$

Repeatability :  $\pm 1\%$

Detection Level :  $\pm 1\%$

Calibration : Amps R.M.S.

Range : 2 to 20% continuous

Trip delay : 5 sec

### Start Per Hour Limiter

Level Setting Accuracy :  $\pm 4\%$

Linearity:  $\pm 4\%$

Repeatability :  $\pm 1\%$

Calibration : Starts per hour

Range : 1 to 12 per hour

### Short Circuit Sensor

Tripping Level : 10,5 to 11,2 x max load dial setting

Tripping delay : 100ms

### Overload Trip Delay Curves

\* See NewElec 320M Series running curve Accuracy

:  $\pm 5\%$  for 125 to 1100% overload

:  $\pm 10\%$  for 102 to 124% overload

:  $\pm 1\%$  for 101% overload

### Maximum Load Current Setting

Level Setting Accuracy :  $\pm 4\%$

Linearity :  $\pm 4\%$

Repeatability :  $\pm 1\%$

Detection Level :  $\pm 1\%$

Calibration : Amps R.M.S.

Range : 21 : 1 continuous

Response : Related to average of

: 3 input line C.T.'s

### Start Timer

Start Detection : Inrush Current to rise from  
10% to 101% of max load  
current dial setting within 1s

Start Range : 4 to 84s

Automatic transfer from : Occurs when input current  
Start to running curve falls below max load current  
dial setting.

### Earth Fault Sensor

Tripping Level : 10% of motor running load

Tripping Delay : 100ms

### Reset Lockout Time on Overload Trip

Monitor control power on : Lockout Time (Min)

Starts per hour calibration : (60 / (Ns)) Min  $\pm 5\%$   
Selected (Ns)

Monitor Control Power Off : 25 min  $\pm 15\%$

### Main Trip Relay : 5 Amps 220Volt A.C.

Configuration : 1-Form C Common, n/o, n/c

### Auxiliary Relay Contacts

Ratings : 5 Amps 220Volt A.C.

Configuration : 1-Form C Common, n/o, n/c

## Environmental Specifications

### Reference Standards IEC 255

#### Isolation N/O Contact

1KV for 1 minute To IEC 255-5C

#### Impulse Withstand

5KV To IEC 255-4 EIII

### Isolation Seperate Contacts

1KV for 1 minute To IEC 255-5C

### High Frequency

To IEC 255-4 EIII

## Thermal Curves 320 - 327 Series

### 320M – 327M Run Thermal Curves

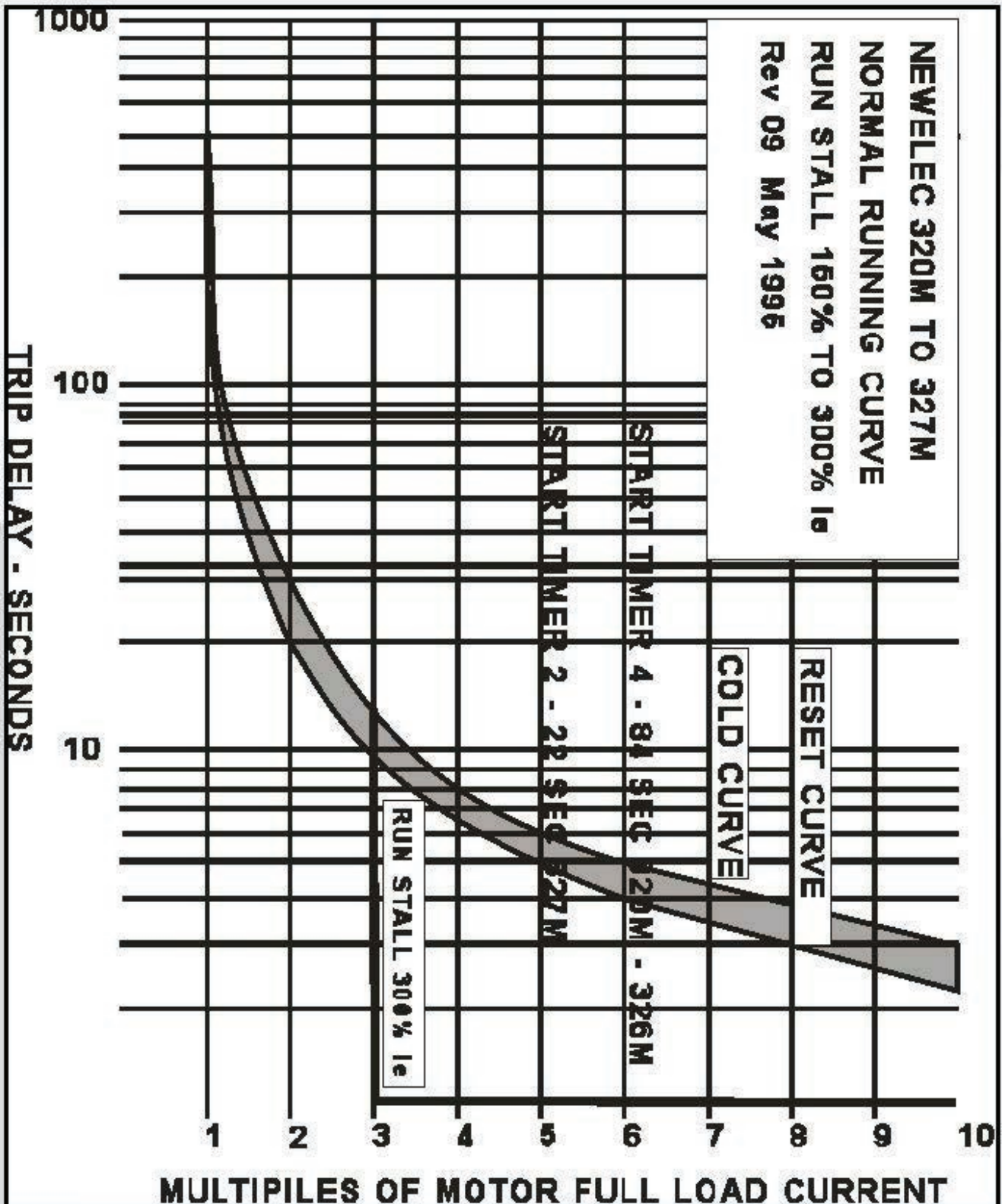

# Wiring Diagram

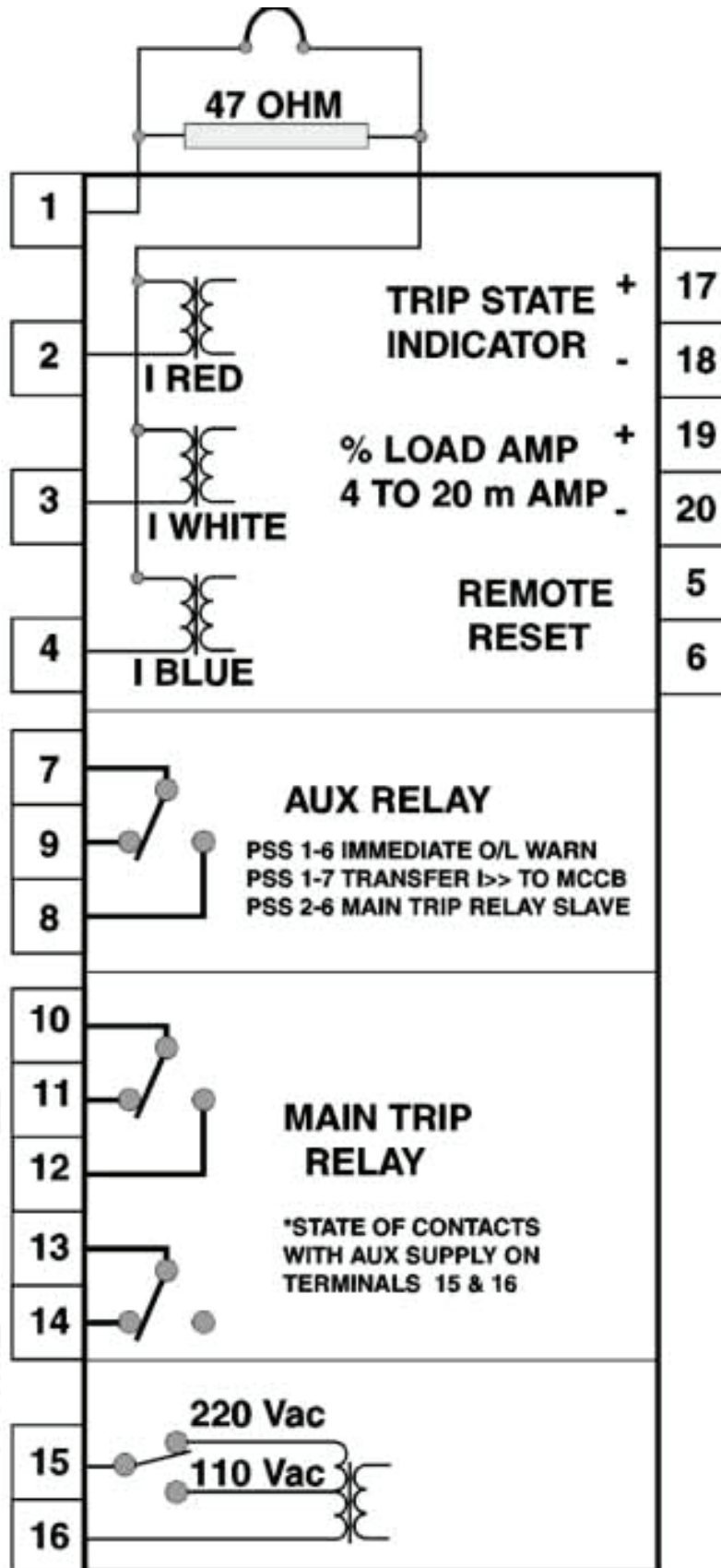

## 320 - 327 Series Dimensions

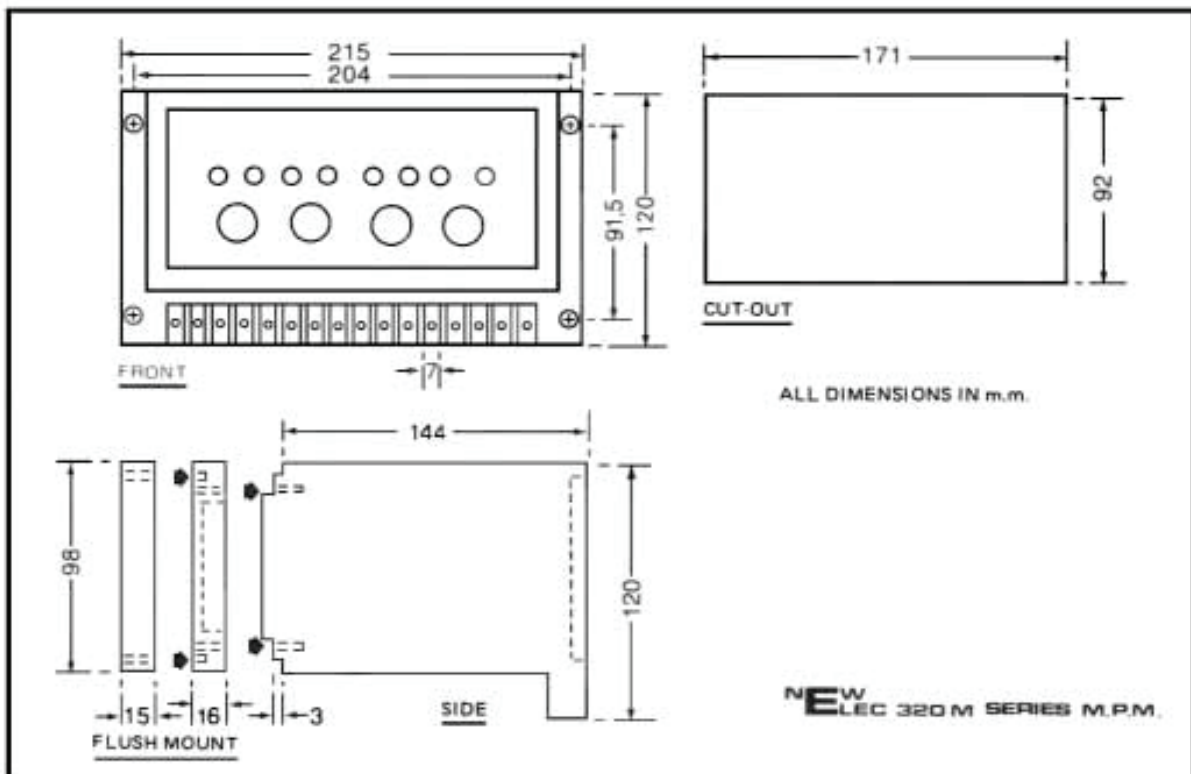
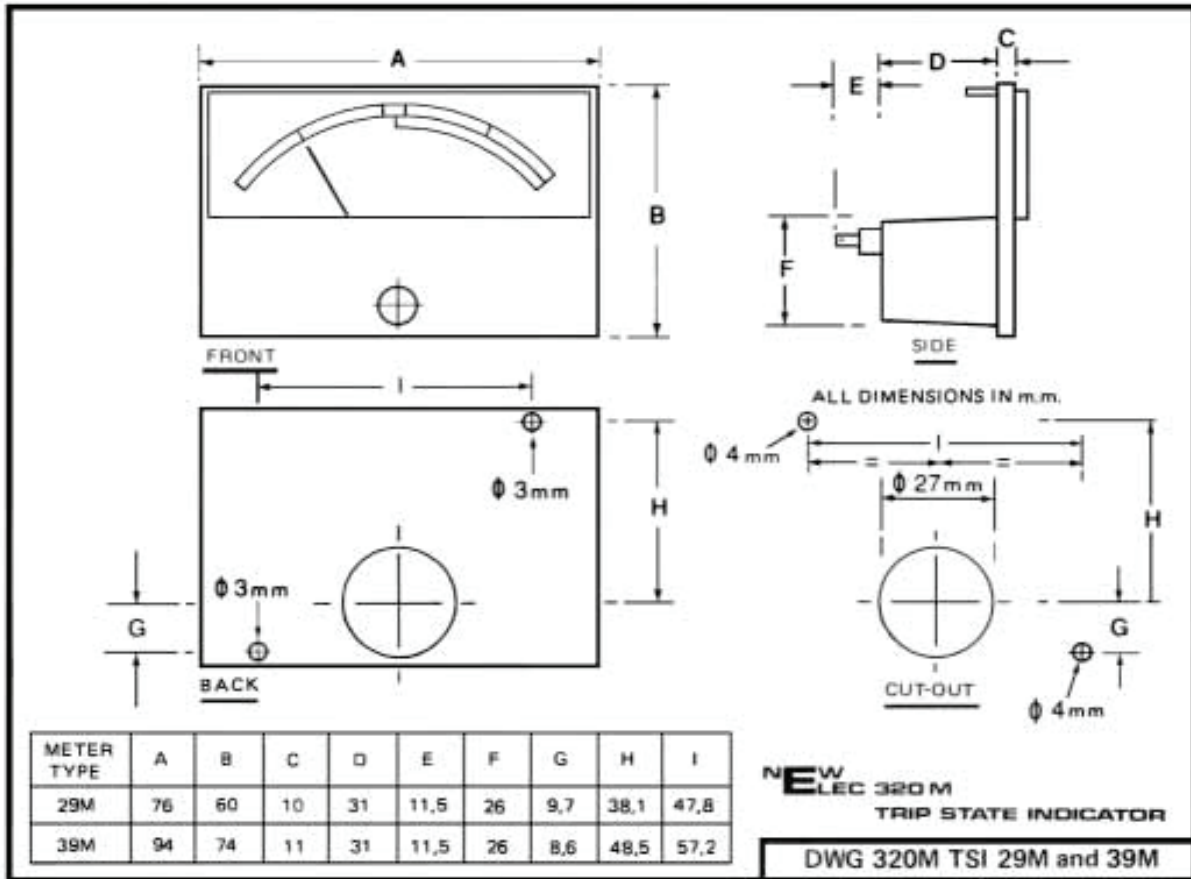

# NEW ELEC

MOTOR PROTECTION & CONTROL TECHNOLOGY

**Physical Address:**

298 Soutter Street,  
Pretoria West

**Tel:** +27 12 327 1729

**Fax:** +27 (0)12 327 1733

**Toll Assist:** 0860 10 30 41

[www.newelec.co.za](http://www.newelec.co.za)

[sales@newelec.co.za](mailto:sales@newelec.co.za)

## 320- 327 Series

**Comprehensive  
Protection for Low  
and Medium Voltage  
Motors**

